

Uson



Zetec Component Testing Solutions

Uson's Custom Approach to Applications. Uson has an application-specific approach for your inspection needs. Starting with your material samples and requirements for flaw detection, Uson designs and builds innovative test solutions. The entire solution is engineered to meet your specifications, from the first feasibility study through design, prototyping and manufacturing. Thorough quality testing is completed before installation at your facility.

Free Feasibility Study Guarantees Results. With a free feasibility study, your real samples are carefully evaluated for detection and test reliability before you make any commitments. Our application specialists have extensive knowledge in eddy current testing and can determine if eddy current is the best solution for your test situation. A formal feasibility report and cost estimate is forwarded to you for your consideration. Budgetary quotations are also available.

Custom Designs Fit Your Process. Uson designs are customized to your application. Let us help you achieve 100% quality inspection. For more information about Uson or our products, visit: www.uson.com

Uson's Zetec eddy current NDE solutions are the result of almost 40 years of market leading experience in safety critical industries.

The relationship between Uson and Zetec combines the non-destructive test experience of two companies who understand the challenges faced in the manufacturing environment.



Achieve 100% Hardness Inspection of Ball and Roller Bearing Components

- 100% in-line process testing at high production rates
- Cut the high cost of failure
- Lower manufacturing and warranty costs
- Meet increased quality requirements
- Fully-automated, real-time process
- Ready-to-install or customized applications
- Flexible/applicable for all production lines

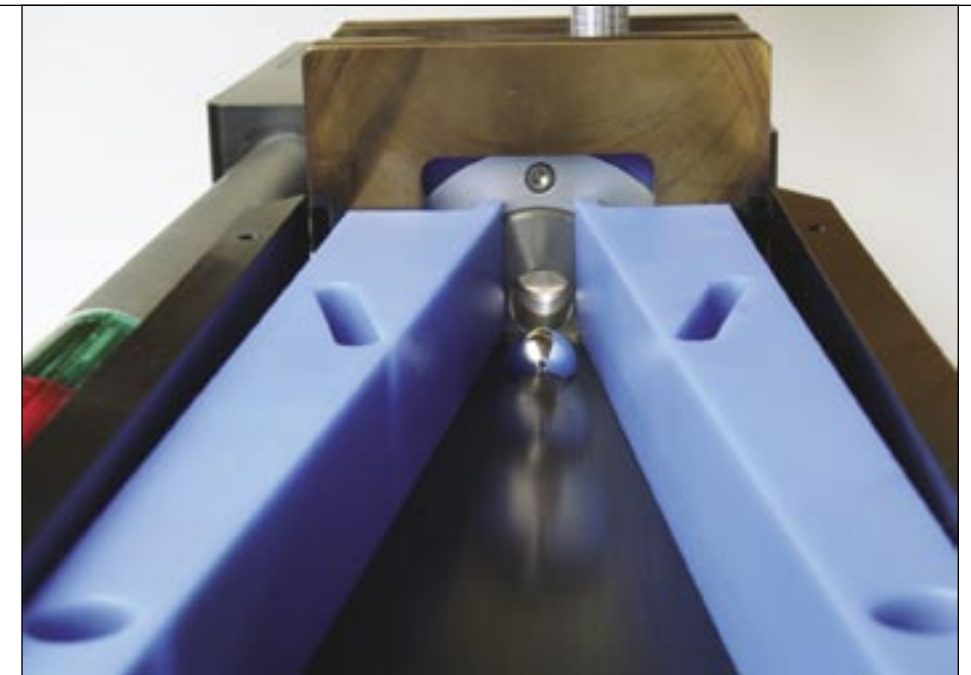

How can you determine a Rockwell 62 hardness from a Rockwell 64 hardness at 7 parts per second?

The only guaranteed way is with eddy current testing.

This remarkable equipment developed for the nuclear power industry allows ball and roller bearing components to be 100% tested to verify correct material properties such as hardness, alloy content and case depth.

Until the development of eddy current tests with superior signal-to-noise qualities for ball and roller bearing components, such conditions were only detectable with costly and time-consuming destructive testing.

Even rigorous sampling can miss statistically unpredictable or previously unencountered defects.

As the demand for production line quality grows, your need to ensure zero defect bearing components is of ever increasing importance.

Uson

Uson LP
Component Testing Solutions
8226 Bracken Place S.E.
Suite 100
Snoqualmie, WA 98065
U.S.A.
Tel: +1 425-974-2905
Fax: +1 425-974-2897
Email: eddycurrent@uson.com

www.uson.com

Printed in the USA

United States | United Kingdom | Germany | China

Eddy Current Testing Permits Every Bearing Component To Be Fully Tested—Without Slowdowns in the Production Line

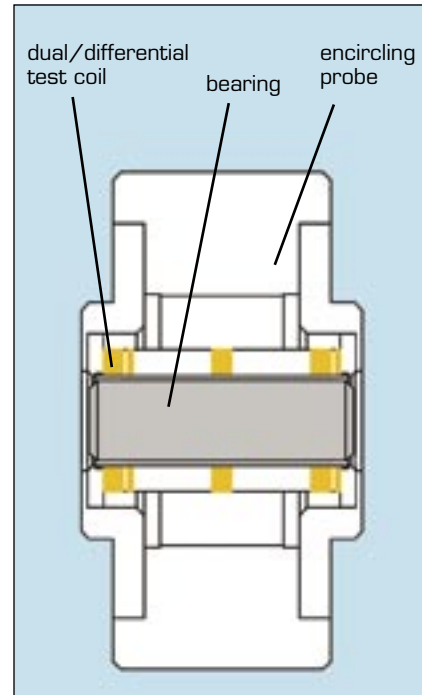

Dynamic inspection of pinion or roller bearing.

Bearing components can have hidden structural problems that will shorten product life. Improper heat-treating can ruin an entire production batch. One bad part in a bearing can ruin that bearing prematurely. Once an undetected bad bearing is installed in a larger assembly, your warranty liability increases further.

"The equipment is very good at detecting hardness at high rates of speed. ... I'm well pleased with the equipment."

— Major bearing manufacturer

When a Zetec Automated Bearing Hardness Inspection System is in place, every bearing can be tested without production line slowdown. That makes zero defects not just a goal but also an affordable reality.

Non-Stop Hardness Testing. Uson's Zetec eddy current test system with "dynamic throughput" can evaluate all bearing components for hardness during the actual manufacturing process. More than 25,000 bearings/hour can pass through encircling coils that detect conditions such as short or no heat treatments, improper quench or material mix. Eddy current testing is specifically tailored to provide maximum detection while achieving maximum production throughput. The test procedures can also conduct real-time process validation without waiting for sample tests or destructive tests of bearings.

More than testing every bearing, Uson can provide tabletop sorters and other sorting solutions that clearly separate good parts from bad ones, assuring zero defects.

Manufacturing Verification. The process of verifying manufacturing processes goes beyond inspecting the quality of the parts alone. Eddy current inspections can also assure that every ball is present in a race of bearings. The system is self-contained and includes all aspects for inspecting, material handling, data acquisition and network connectivity.

In-Line Bearing Inspection Systems. Uson can supply off-the-shelf and custom-designed coils and instruments for specific quality assurance applications. Or, we can supply a complete turnkey operation for your factory. Uson automated systems provide complete I/O capability allowing the separation of "good vs. bad" bearings so every defective bearing is clearly identified and sorted.

In addition, our rugged and reliable eddy current test equipment can be mounted within environmental enclosures designed to operate in harsh factory environments.

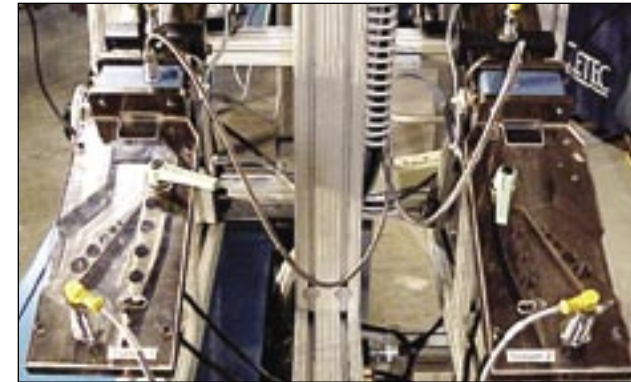

Uson can supply a complete turnkey operation with material handling and data acquisition to your factory specifications.

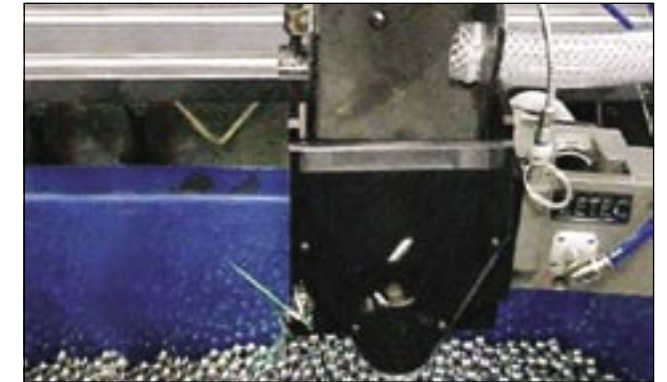

At rates of up to 25,000 per hour, the automated Zetec system can separate good parts from bad.

Perfect Choices for the Job. The powerful InSite, MIZ[®]-23 and MIZ[®]-27CT are state-of-the-art platforms utilizing electronics developed for the nuclear power industry and offering the best in eddy current testing. The MIZ-23 is a single-coil/single-frequency test unit while the MIZ-27CT can support multiple test coils at multiple frequencies.

Four independent frequency readings enable the MIZ-27CT to maximize the difference between acceptable and rejected parts. Moreover, up to 25 test configurations for different bearing sizes and conditions can be permanently stored.



The same high precision electronics developed for use in the nuclear power industry are featured in the MIZ-27CT instrument.