

The Problem

Products such as one-way valves are often built to open at a certain pressure. Product and test engineers need to know at what pressure the valve starts to open (cracking pressure) and if the valve body breaks.

Typical leak testers cannot determine the cracking pressure because they use merely one pressure sensor upstream from the product being tested. The upstream sensor is constantly supplied with air, so sensing the downstream pressure change is next to impossible.

Such typical leak testers also cannot reverse the pressure going to the two sides of the product to perform a bidirectional leak test.

The Solution

The Sprint iQ bidirectional check valve tester is equipped with a precision flow control and two pressure sensors. All components are contained in Sprint's small enclosure.

The downstream sensor detects precisely when the product opens and starts to flow air. This tells test engineers exactly what pressure the device is being tested starts to crack open.

The Sprint iQ bidirectional check valve tester can also reverse the air flow to determine how well the valve holds pressure on the B-side of the product.

This standard option is another example of why Sprint iQ is much more flexible than any other leak tester you can buy.

How It Works

The Bidirectional check valve testers work like this:

- The product is attached to both test ports (Figure 1)
- Sprint iQ slowly pressurizes the A-side of the product through the flow control [FC]. Pressure applied to the A side of the product is measured upstream by sensor [S1].
- The downstream sensor [S2] waits to measure a pressure from the B-side of the product.
- When pressure measured downstream reaches the set threshold, Sprint iQ stops the test and displays the pressure applied to the A-side of the product (peak ramp pressure)
- Optionally, the user can link tests to have Sprint iQ reverse the pressure sequence and have sensor [S1] wait to detect a pressure increase from the A-side of the product or perform a standard leak test on the B-side of the product.

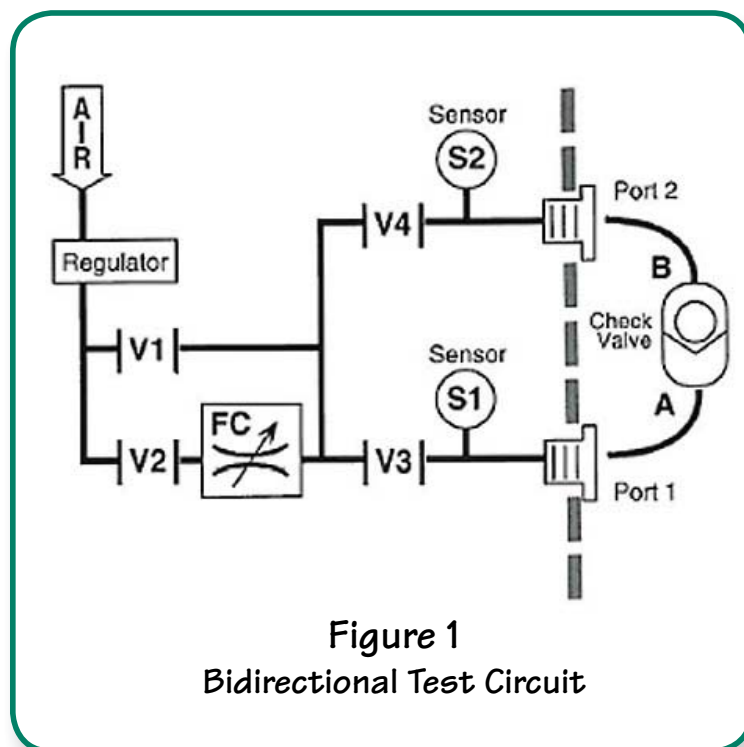
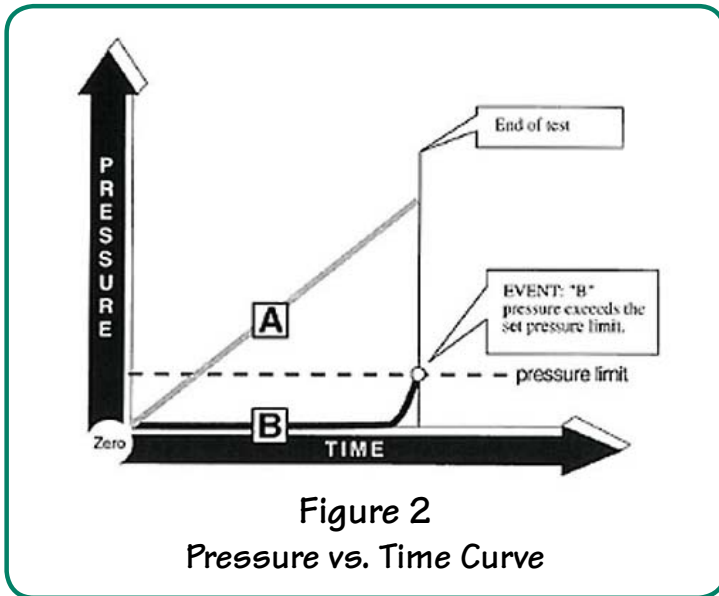

Figure 1
Bidirectional Test Circuit



Pressure and Time Sequence

Pressure slowly ramps up through the flow control and pressurizes the upstream side of the product. Curve [A].

During the gradual pressure increase, the pressure measured on the downstream side of the product remains near zero. Curve [B].

The leak tester's downstream sensor looks for the slightest pressure above zero at the B side of the product. When the pressure exceeds the preset pressure limit (dashed line), the EVENT is detected and Sprint iQ stops the test.

If the downstream sensor does not detect an event (pressure exceeding the pressure limit within the established test time), the program times out and Sprint iQ shows NO CRACK in the status box on the LCD display.

Applications

The check valve tester is valuable when testing duck-bill valves, check valves, pinch valves or devices that open slowly under applied pressure.

You can use the Sprint iQ bidirectional check valve tester to check for both cracking pressure and for body leaks in the valve body.

This machine can be used to perform normal pressure decay tests on either test port. Bypass valve [V1] is used as a fast-fill valve in pressure decay testing.

A variation of the bidirectional configuration tests product in one direction. See the separate Uson Application Note describing the downstream sensor option.

Features

- Valving to re-direct air to both product sides
- Built-in adjustable precision flow control
- Performs standard pressure decay tests
- Detects cracking pressure and body leaks
- Links programs to perform multiple tests
- Small footprint (8.5 by 15 inches)
- Perfect for bench or automation
- Pressure resolution as high as 0.001 psi
- Easy to program and calibrate

Uson L.P.

8640 N. Eldridge Parkway
Houston, Texas 77041
USA

Phone: +1-281-671-2000

Fax: +1-281-671-2001

info@uson.com

www.uson.com