

The Problem

Manufacturers of multi-lumen catheters face a demanding task when testing them. The test typically checks each lumen in the catheter to make certain nothing leaks. Each passageway must also be tested for possible blockage or partial occlusion.

Added to these concerns, the tester must be cost-effective so numerous stations can be implemented for increased production output.

Custom-built catheter testers, sometimes assembled from computers and various measuring equipment, can often become an unmanageable collection of difficult-to-operate and difficult-to-maintain components.

The Solution

Sprint iQ can be configured as a four-channel sequential tester incorporating everything needed to test multi-lumen catheters for leakage and occlusion. The machine checks for leaks in fittings, leaks through the outside catheter wall, interlumen leaks, and occlusion with each lumen.

When testing one lumen, all other lumens are opened to atmosphere through Sprint iQ's 3-way valves. This makes it possible to test leakage between adjacent passages in the catheter.

Sprint iQ catheter testers cost much less than a custom array of separate instruments, so users can install multiple stations to increase throughput.

How Sprint iQ Works

The Sprint iQ catheter tester works like this:

- The product is attached to each test port (Figure 1) and the Sprint iQ's test program is started.
- The distal end of the catheter is sealed to block skives and other openings (Figure 2).
- Air is supplied at test pressure to Sprint iQ's output port through valve V1. Valves V2, V3 and V4 are opened to atmosphere.
- The first lumen, L1, is leak tested. If the other lumen leaks to the outside or to any other lumen (shown in the example to lumen 4), Sprint iQ detects the leak.
- Each additional lumen (L2 through L4) is leak tested in sequence.
- After leak testing, the sealing clamp can be removed from the catheter and Sprint iQ can check each lumen for occlusion.

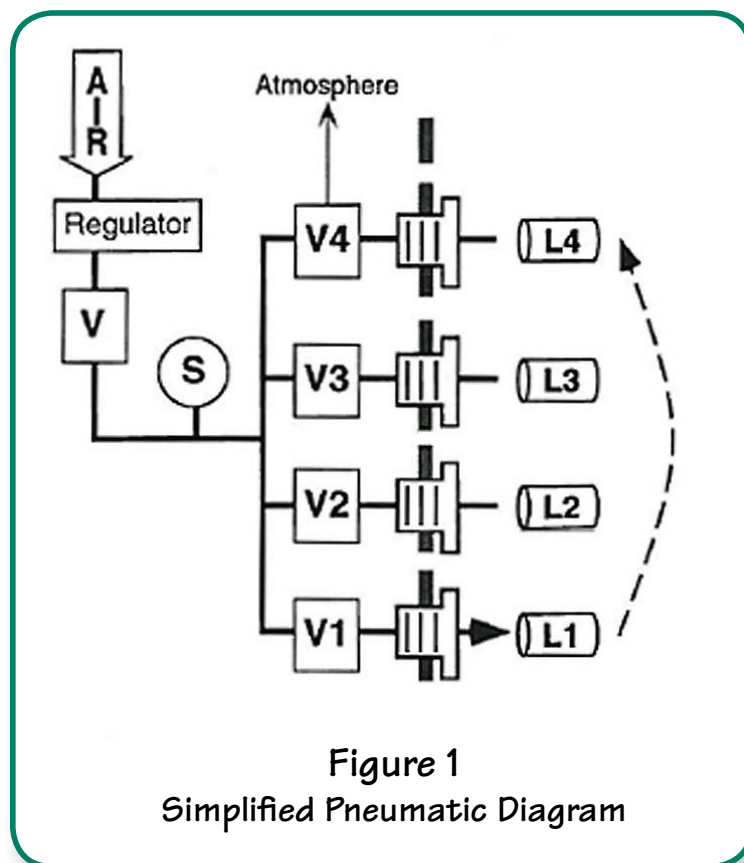
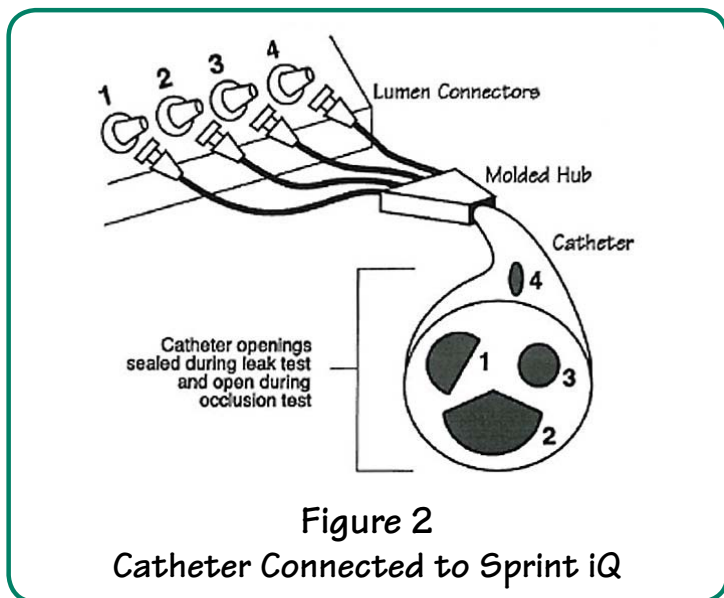

Figure 1
Simplified Pneumatic Diagram



Clamping

To leak test a finished catheter, the opening in the distal end is typically closed off with an external sealing figure. The catheter can then be checked for interlumen leaks. Please see Figure 2.

Occlusion Test

Occlusion tests can be performed individually after each lumen is leak tested, or all at once after all lumens have been tested.

When testing for occlusion, the sealing device is removed from the catheter to allow the lumen to flow to atmosphere. During an occlusion test, Sprint iQ looks for the pressure to drop below a preset threshold to verify that the passage is not blocked. Please see the Application Note titled *Occlusion Testing*.

Sprint iQ can be set up to test in any sequence by linking individual pressure decay and occlusion programs.

Applications

The Sprint iQ 4-Channel sequential tester is ideal for evaluating multi-lumen catheters. The tester can also check any product that has multiple parts or multiple passages (up to four) that can be tested in sequence. In addition, the Sprint iQ 4-channel sequential tester can be used to test as many as four individual products in sequence.

To test catheters with fewer lumens, Sprint iQ models are available also in two and three channel configurations.

All data concerning the operation of this tester cannot be included in this brief application note. We invite you to call Uson to discuss how a Sprint tester can be applied to your specific testing needs.

Features

- Tests passages in one integrated sequence
- Checks passages for leaks and occlusions
- Tests 1, 2, 3, or 4 parts in sequence
- Fully calibrated and simple to maintain
- Outstanding pressure and flow resolution
- Small footprint (8.5 by 15 inches)
- User-selectable engineering units
- Large back-lighted color display
- Interface for statistical process control
- Full set up menus on one screen.

Uson L.P.

8640 N. Eldridge Parkway
Houston, Texas 77041
USA

Phone: +1-281-671-2000

Fax: +1-281-671-2001

info@uson.com

www.uson.com