

### The Problem

Test and production engineers are often faced with the task of detecting leaks in products quickly, accurately, and inexpensively.

Mechanical pressure measuring devices such as tube and bellows pressure gauges are insensitive, slow and do not have time or control functions. Dunk testing (looking for bubbles under liquid) is time consuming, cumbersome, and subject to operator errors.

On the other hand, overly complicated leak testing equipment is probably too elaborate for the task. Custom-designed computerized test equipment is frequently expensive and difficult to program.

### The Solution

Uson pressure decay testers work like a pressure gauge, except they have a high-resolution digital readout, timers, and limit settings. For example, imagine an analog gauge with a resolution of 0.001 psig, and setpoints to determine an allowable drop in pressure (see Figure 1).

If pressure drops below the reject setpoint, the product is considered bad. If the pressure remains above the reject level, the product is considered good.

Although a Uson leak detector is much more elaborate than this example, it illustrates the concept of pressure-drop testing.



Figure 1

### How It Works

A pressure decay tester works like this:

- The product is attached to the test port and the test is started (See Figure 2).
- The tester pressurizes the part with the fast-fill valve [V1] (if used). Fast fill pressure is set with a separate regulator and analog gage on the rear of the tester.
- At the end of fast fill time, the product is pressurized through valves [V2] and [V3].
- Trapped air pressure inside the test circuit is measured by a pressure sensor [S].
- If product exceeds the programmed leak tolerance (pressure drop over time), The display shows why the product failed and displays the pressure loss in user-defined engineering units (Figure 3).
- At the end of test time, pressure is vented to atmosphere through the dump valve [V2], and the tester is ready to make the next test.

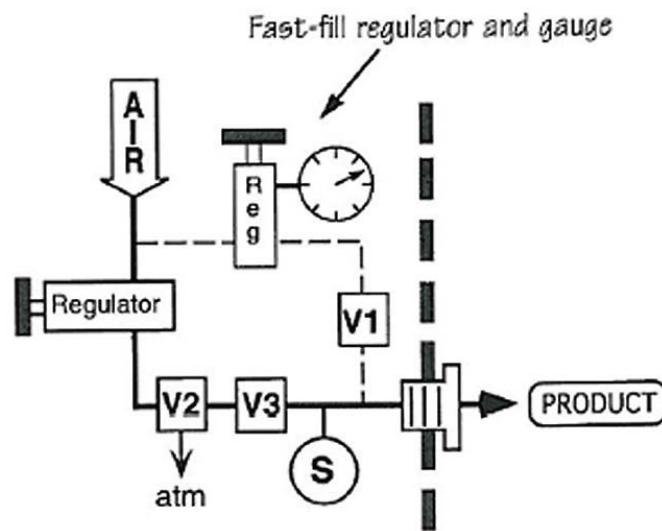
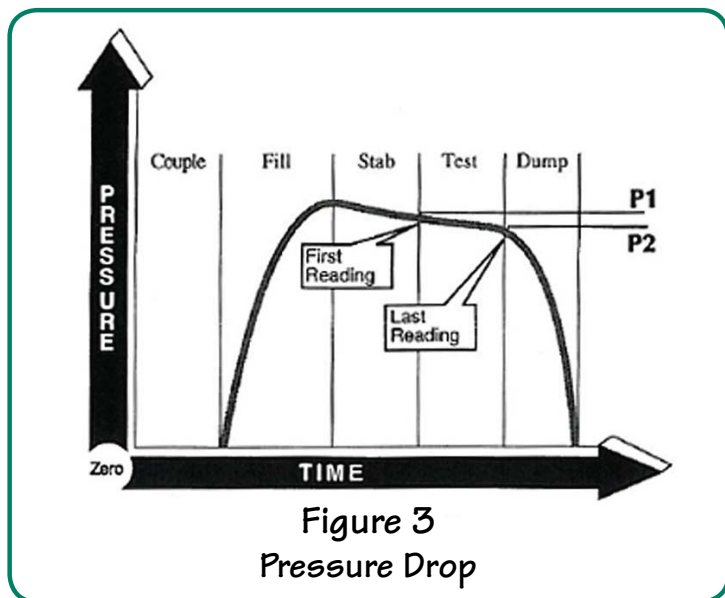

Figure 2  
Pressure Decay Pneumatic Diagram



**Figure 3**  
Pressure Drop

### Pressure Drop Curve

Pressure drop is the amount of pressure change from the first pressure movement in test phase (P1), to the last pressure movement in test phase (P2). (Figure 3)

Decay rate is the pressure drop divided by the test time:

$$\frac{P1 \text{ minus } P2}{\text{Test Time}} = \text{Decay Rate}$$

### Display

Showing the status during each test, the display indicates fill, stabilization, test and dump during the respective cycle period.

In an automated operation, the pass and fail information is sent to the I/O port on the back of the tester.

### Applications

Uson pressure decay testers are frequently used to test parts that were previously tested using simple analog pressure gauges or were tested by looking for escaping gas bubbles.

You can use the leak tester to test both large and small volume parts. If a large part is tested, the optional fast-fill valve and regulator quickly inflate the product. Fast fill pressure is controlled by a separate air regulator and gauge mounted on the back of the machine. If possible, direct line pressure can be supplied through the fast fill valve to the product (Figure 2).

Need to test a flexible product? No problem. Uson pressure decay testers are used to test products that are rigid or flexible. If testing flexible product, fill and stabilization timers are adjustable to increase the repeatability and accuracy of the test.

### Features

- Simple and durable configuration
- Tests large or small volume parts
- Tests flexible and rigid parts
- Available in a wide range of test pressures
- Optional electronic regulator
- Perfect for bench or automation
- Many special options are available
- Resolution to 0.001 psi at 60 psi full scale
- Easy to program and calibrate
- Off-the-shelf delivery

# Uson

for good measure

### Uson L.P.

8640 N. Eldridge Parkway  
Houston, Texas 77041  
USA

Phone: +1-281-671-2000

Fax: +1-281-671-2001

info@uson.com

www.uson.com